

# 3HXOL,3HX 系列鐵弗龍 Fluoropolymer 加熱器

具有卓越的耐化學腐蝕性  $10\text{w/in}^2(1.5\text{w/cm}^2)$

## 鐵弗龍加熱器優勢：

- 不銹鋼元件包覆厚壁 Fluoropolymer (PTFE) 為耐用的設計。
- 低功率密度設計佔用空間極小以確保長使用壽命。
- 內含溫度保護以提供安全操作。

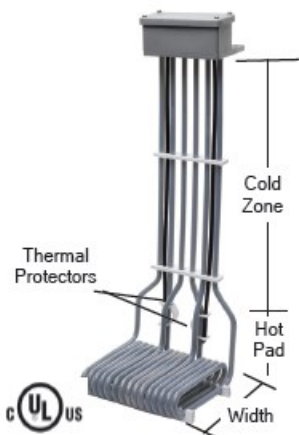

3HXOL 系列 L 型三組式鐵弗龍(PTFE)加熱器

WATTS	VOLTS	WIDTH In./(mm)	HEATER PAD LENGTH In./(mm)	STD.VERT LENGTH In.(mm)	MAX. COLD ZONE In.(mm)	MODEL NUMBER	SHIP WGT. Lbs.(kg)
3000	240	8	13	18	36	3HXOL3208-13-R** 3HXOL3408-13-R**	20 (9.1)
	480	(203)	(330)	(460)	(915)		
4500	240	10.5	11	18	35	3HXOL4.5210.5-11-R** 3HXOL4.5410.5-11-R**	21 (9.5)
	480	(263)	(280)	(460)	(890)		
6000	240	10.5	19	18	35	3HXOL6210.5-19-R** 3HXOL6410.5-19-R**	22 (10)
	480	(263)	(485)	(460)	(890)		
9000	240	10.5	23	18	35	3HXOL9210.5-23-R** 3HXOL9410.5-23-R**	36 (16.3)
	480	(263)	(585)	(460)	(890)		
12000	240	10.5	30	18	35	3HXOL12210.5-30-R** 3HXOL12410.5-30-R**	42 (19.1)
	480	(263)	(760)	(460)	(890)		
15000	240	10.5	36	18	31	3HXOL15210.5-36-R** 3HXOL15410.5-36-R**	48 (21.8)
	480	(263)	(915)	(460)	(790)		
18000	240	10.5	42	18	25	3HXOL18210.5-42-R** 3HXOL18410.5-42-R**	54 (24.5)
	480	(263)	(1070)	(460)	(635)		

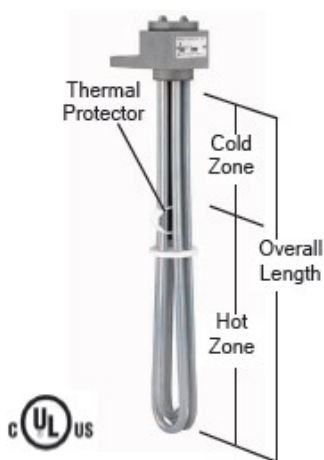

3HX 系列三件繞管式鐵弗龍(PTFE)加熱器

WATTS	VOLTS	HOT ZONE In./(mm)	OVERALL LENGTH In.(mm)	MODEL NUMBER	SHIP WGT. Lbs.(kg)
1000	120	10	17	3HX1117-1** 3HX1217-**	10 (4.5)
	240	(254)	(432)		
1500	120	16 (406)	23 (584)	3HX1.5123-1**	11 (5)
	240			3HX1.5223-**	
	480			3HX1.5423-**	
2000	120	22 (559)	29 (737)	3HX2129-1**	12 (5.4)
	240			3HX2229-**	
	480			3HX2429-**	
3000	240	29 (737)	35 (890)	3HX3235-**	14 (6.4)
	480			3HX3435-**	
4000	240	39 (991)	47 (1194)	3HX4247-**	17 (7.7)
	480			3HX4447-**	
5000	240	48 (1219)	59 (1499)	3HX5259-**	20 (9.1)
	480			3HX5459-**	
6000	240	56 (1422)	68 (1727)	3HX6268-**	23 (10.4)
	480			3HX6468-**	

集安電工有限公司 [www.atapowtech.com](http://www.atapowtech.com)

TEL:886-3-3666021 FAX:886-3-3626423